

■ Operating and installation instruction

REMKO PGM (E) series Propane gas heating systems

PGM 30 (E), PGM 60 (E)



This product is not suitable as a main heater.

Contents

<i>Safety notes</i>	4
<i>Unit description</i>	5
<i>Installation instructions</i>	6
<i>Gas connection</i>	7-9
<i>Commissioning</i>	9-10
<i>Shutdown</i>	11
<i>Care and maintenance</i>	11-12
<i>Troubleshooting</i>	13
<i>Intended use</i>	14
<i>Customer service and guarantee</i>	14
<i>Environmental protection and recycling</i>	14
<i>Exploded view of PGM 30</i>	16
<i>Spare parts list for PGM 30</i>	17
<i>Exploded view of PGM 60</i>	18
<i>Replacement parts list for PGM 60</i>	19
<i>Maintenance protocol</i>	20
<i>Technical data</i>	21
<i>Electrical wiring diagram</i>	22



Carefully read this operating manual prior to commissioning/using the unit!

This operating manual is a translation of the German original.

These instructions are an integral part of the unit and must always be kept in the vicinity of the installation location or on the unit itself.

Subject to modifications; no liability accepted for errors or misprints!

REMKO PGM (E) series

Safety notes

Always observe the respective local building code and fire prevention guidelines as well as the guidelines of the accident prevention and insurance associations when using the units.

The units have been subjected to extensive material, functional and quality inspections prior to delivery. However, dangers can arise from the units if they are used improperly or not as intended by untrained personnel! Please observe the following information:

- The units may only be operated by persons that have been instructed in their operation
- The power plug must be pulled out of the mains socket before maintenance and repair work
- The units must be installed such that they are stable on a non-combustible surface
- It is necessary to ensure that no flammable objects or materials can be drawn in
- This unit can be used by children above the age of 8, as well as by people with impaired physical, sensory or mental capabilities or a lack of experience and knowledge if they are supervised or have received instruction in the safe operation of the unit, and if they understand the associated potential hazards. Children must never play with the unit.
- Cleaning and user maintenance must not be carried out by unsupervised children.
- The units must be installed and operated in such a way that personnel are not endangered by exhaust gases and radiant heat and no fires may occur
- Portable liquid gas tanks must be installed such that they are **stable** and **upright**
- Liquid gas tanks must never be used whilst lying horizontal during unit operation
- All unit electrical cables must be protected against damage, e.g. by animals
- The units must then only be operated in areas where the units can be supplied with an adequate amount of air for combustion
- The units must only be installed in well-ventilated spaces and away from flammable materials. Personnel must not remain in the installation area **Appropriate prohibition signs should be put up at the entrances!**
- A safety zone of 1.5 m must be maintained around the units, incl. to non-combustible items
- A minimum distance of 3 m must be maintained from the unit outlet
- The unit outlet must not be restricted or fitted with hoses or pipes
- Never insert foreign objects in the unit

- The air intake grille must always be kept free of dirt and loose objects
- The units must not be exposed to direct jets of water e.g. **pressure washers, etc.**

⚠ CAUTION

The units must not be used for heating living spaces in residential buildings.

⚠ CAUTION

If there is a gas leak, immediately close the shut-off valve to the gas supply system, switch off the gas heater, unplug the power plug, open windows/doors for ventilation and seek the cause of the gas leak in order to neutralise this. Do not use the unit again before the gas leak has been eliminated!

Unit description

The units are mobile fan-assisted air heaters (WLE) directly fired with liquid gas, without a heat exchanger.

The units operate without an exhaust gas connection and are designed exclusively for commercial use.

The units are equipped with integrated power regulation for the stepless control of the heating capacity, quiet and low-maintenance axial fans, robust gas burners with thermal monitoring, electric solenoid valve, piezo ignition and mains cable with earthed safety plug.

The units are intended exclusively for manual operation and cannot be thermostatically controlled.

The units conform to the fundamental health and safety requirements of the appropriate EU stipulations and are simple to operate.

The units are EC type-tested, DVGW-registered and approved for EU countries.

The units may be used among other things for the following:

- Drying newly completed buildings
- Spot heating of outdoor workplaces
- Spot heating workplaces in open, non-flammable manufacturing facilities and halls
- Temporarily heating enclosed spaces with a sufficient fresh air supply
- De-icing machines, vehicles and non-combustible warehoused goods
- Maintaining the temperature of frost-sensitive parts

Operating sequence

After switching on the units, the supply air fan is put into operation and the electric solenoid valve is opened.

However, the gas supply to the burner remains closed at this point.

Only after actuating the pressure pin of the safety pilot is the gas supply to the gas burner enabled. The liquid gas is now transported through the gas nozzle under pressure into the mixing tube. Here, the liquid gas is enriched with a quantity of oxygen determined based on the respective burner output.

The gas/air mixture produced in this way is ignited at the burner head by an electric ignition spark. The ignition spark is generated through the manual actuation of the piezo igniter.

The heating of the thermocouple activates the thermal monitoring of the flame in operation.

The pressure pin of the safety pilot must now be released.

In the event of any irregularities or if the flame is extinguished, the gas supply is interrupted.

A safety temperature limiter (STB) interrupts with an overheating of the gas supply and interlocks all unit functions.

Regulation of the min/max heating capacity can be implemented on a stepless basis during unit operation on the integrated "power regulation".

NOTE

For optimum operation the units should not be operated above an ambient temperature of 25 °C.

Monitoring the units

It is possible to safely monitor all functions with the safety devices of the units.

In the event of irregularities or if the flame is extinguished, the units are switched off and interlocked.

Safety temperature limiter (STB)

The units are equipped with a safety temperature limiter (STB), which interrupts the gas supply in case of overheating and electrically interlocks the unit.

A manual reset of the STB can only be implemented after the units have cooled down.

CAUTION

If the safety temperature limiter has been triggered, the cause of the malfunction must be identified and rectified before a reset is performed.

The STB is reset by actuating the reset key 2.

1. Unscrew the protective cap 1.

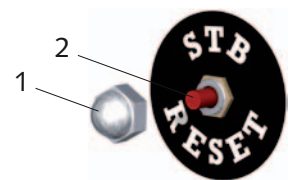

2. Push in the pressure pin 2.
3. Screw the protective cap 1 back on again.

CAUTION

Safety devices must not be bypassed or disabled.

REMKO PGM (E) series

Installation instructions

The safety regulations of the accident prevention and insurance associations, the respective regional building regulations and the combustion appliances regulations apply to operation of the units.

For example, for Germany:

- Combustion plant order (FeuVo) for the individual federal states
- Accident prevention regulations DGUV Regulation 79 "Use of liquid gas"
- Workplace directives ASR 5
- Workplace regulations §§ 5 and 14

Outdoor installation

- The operation of the units must not present a hazard or unreasonable loading
- The unit operator must ensure that it is not possible for unauthorised persons to manipulate either the unit or the power supply
- To prevent damage due to inclement weather, units installed outdoors must be adequately protected

Installation in enclosed, well-ventilated rooms

- The units are designed without an exhaust gas connection according to type, and can only be used in enclosed rooms on a conditional basis
- Reliable extraction of the combustion gases must be guaranteed in all cases in order to exclude impermissible contamination of the room air with hazardous substances

- The fresh air supply required for trouble-free combustion must be ensured. It is practical to have the fresh air supply provided by windows and doors or through appropriately dimensioned openings in the outside wall

- The units must not operate continuously whilst unattended

The units may only be operated in rooms if:

- a sufficient quantity of air is supplied to the units for the combustion
- these are well ventilated and aerated
- the proportion of substances harmful to health in the breathing air is at a harmless level

There is good natural ventilation and aeration if:

1. the room volume in m³ is at least 30 times the nominal heating capacity kW of all of the units operating in the space, and if the natural change of air is guaranteed by windows and doors or
2. constantly open ventilation openings are present for incoming and exhaust air in the vicinity of the ceiling and floor, whose size in m² is at least 0.003 times the nominal heating capacity in kW of all of the units operating in the space.

⚠ CAUTION

For use in public buildings, national regulations must be observed.

⚠ CAUTION

The units must only be installed in well ventilated spaces and not in living areas or similar recreational areas.

Gas connection

The gas connection / unit operation must take place exclusively on the basis of the accident prevention regulation DGUV 79 "Use of liquid gas", as well as the respective local construction and fire prevention regulations.

The fuel supply must be installed in accordance with DIN 4755 for oil-fired warm air heaters, DVGW Code of Practice G 600 for gas-fired warm air heaters and TRF for liquid gas.

The units are operated with liquid gas in accordance with DIN 51622. They require a constant unit connection pressure of 1.5 bar. It is prohibited to exceed or undershoot the connection pressure.

⚠ CAUTION

A constant unit connection pressure of 1.5 bar (1500 mbar) must be guaranteed, also in continuous operation.

- When using longer hose lines, consider the respective pressure loss
- Only use components that have been tested and are suitable for the respective purpose, such as gas hose, pressure controller and hose breakage protection or leak gas protection
- If possible, the length of the gas hose should not exceed 2 m
- Only pressure controllers with a fixed outlet pressure setting are permitted. The units may only be operated out of the gas phase

⚠ CAUTION

Before all work on the gas supply and when replacing gas cylinders, all shut-off valves must be closed and no ignition sources are permitted in the immediate vicinity.

- The use of longer hose lines is permissible if:
 - special operational reasons exist
 - appropriate additional safety measures are observed and the hose lengths are kept as short as possible
- Hose lines must be fundamentally protected against chemical, thermal and mechanical damage
- In particular, torsional stress must be avoided
- The units may only be operated out of the gas phase
- The units must be serviced by qualified persons only
- Only original spare parts may be used for repairs
- Unit parts that are prone to wear and ageing (e.g. gas hoses) must be replaced at regular intervals
- Gas connection nipple on the unit - G1/4 LH - KN
- When selecting the hose, make sure that the pressure class is sufficient

- All common gas cylinder sizes are permitted for the gas supply. However, a gas cylinder with at least 11 kg filling weight is recommended. For longer operation and nominal heat outputs above 50 kW, it is recommended that the gas be drawn from several gas cylinders in parallel. (Multi-cylinder accessories set)

💡 NOTE

This does not apply if the correct condition is confirmed by an expert.

⚠ CAUTION

*The units must not be used **below ground level**, e.g. in basements, without suitable gas monitoring equipment.*

💡 NOTE

It is prohibited to exceed or undershoot the required connection pressure.

REMKO PGM (E) series

Connecting the gas supply

1. Connect pressure controller to the gas cylinder or gas supply system.



Observe left-handed thread!

2. Open cylinder valve(s) or shut-off valve of the supply line.



With simultaneous discharge from multiple gas cylinders, all valves must be opened.

3. Push the unlock button on the hose breakage protection after opening the valve(s).



This process is also necessary after every cylinder change.

4. Check all gas connections for leak-tightness using suitable media.

for example with:

Soap solution or leak detection spray.



Assembly note

During the assembly or disassembly of the gas hose, it is necessary to **counter-hold** the unit by the **gas connection nipple** with an open-end wrench size 17, whilst observing the left-handed thread.

This process also applies to the pressure controller, hose breakage protection and all further gas components.

Tighten gas hose:

Turn the union nut **anticlockwise**

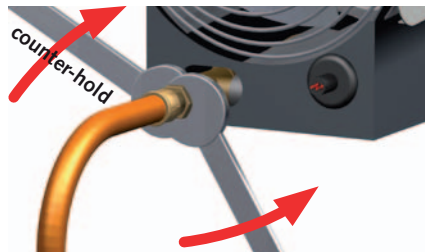

Loosen gas hose:

Turn the union nut **clockwise**

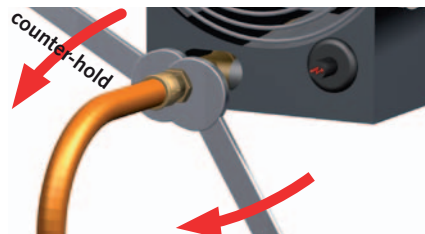

Icing up of gas cylinders

With insufficiently dimensioned gas supply systems, there is a risk of the pressurised gas cylinder icing up.

Due to the reduction of the gas pressure, it is no longer possible to guarantee the correct gas supply to the unit.

Crystalline frost formation on the gas cylinder(s) must not be defrosted with naked flames, glowing objects, radiators, etc.

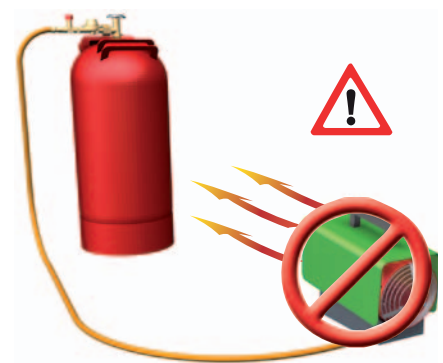

In order to avoid the gas cylinder(s) icing up, it is necessary to configure the gas supply in accordance with the unit connection value, the time in operation and the ambient temperature of the supply tank.

Attachment multi-cylinder set (accessory)

In order to ensure a regular gas take-off insofar as possible, all cylinder valves must be open.

The cylinder battery can be expanded with ease, through the use of additional sets.

Legend:

- 1 = Gas hose to the unit
- 2 = Hose breakage protection
- 3 = Gas pressure controller
- 4 = HP hose 0.4 m
- 5 = T-connection
- 6 = Cylinder valve

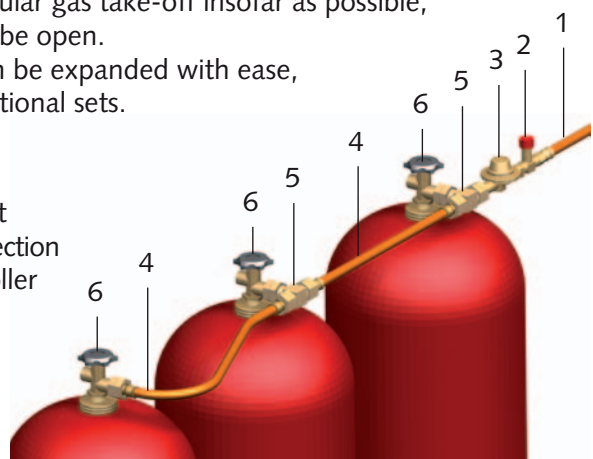

NOTE

Because these are ball nipple screw connections in accordance with DIN 4815, part 2, only appropriate, fitting hoses may be used.

NOTE

Only hoses for liquid gas in accordance with DIN EN 16436-1, pressure class 30 may be used for construction site operations.



Tank gas systems

When connecting the units to tank gas systems, ensure sufficient pipe dimensions depending on the pipe length.

A sufficient gas supply to the consumer system can be ensured through the use of an evaporator.

In order to guarantee the faultless unit function, it is advisable to install a permanently set pressure controller with 1.5 bar outlet pressure and corresponding gas throughput (see unit name plate), as well as a shut-off device tailored and approved for the respective pre-pressure.

In order to avoid malfunctions of the unit's control and safety equipment due to harmful substances such as rust and dust from the gas supply line or tank(s), it has proven to be essential to install gas filters before the control and safety equipment of the units (see DIN EN 676 and TRF 88 section 5).

NOTE

Installation work on the tank gas systems and the supply lines may only be performed by qualified specialist personnel.

CAUTION

Before all work on the gas supply and when replacing gas cylinders, all shut-off valves must be closed and no ignition sources are permitted in the immediate vicinity.

Commissioning

The units should be checked for visible defects on the operating and safety devices as well as proper installation and correct electrical and gas connections before commissioning.

A person, who has been adequately trained in the handling of the units and the use of liquid gas per DGUV 79, must be tasked with operation and monitoring of the units.

CAUTION

In the event of defects that endanger the operational safety of the units, operation of the units must be discontinued immediately and the supervisor informed!

Connecting the units to the electrical power supply

1. Move the operating switch to the "0" (off) position.



2. Connect the unit's power plug to a properly installed and fused mains socket. Connect **230 V/50 Hz**.



NOTE

The electrical connection for the units must be made at a separate feed point with a residual current device in accordance with VDE 0100, Section 55.

Before the unit start, ensure that the gas supply cylinders are correctly secured and are not positioned directly in the heat radiated by the units. The pressurised gas tanks must be positioned to the **side / rear** of the unit.



CAUTION

The tanks must never be heated or de-iced through the unit hot air flow. There is a risk of explosion!

CAUTION

Pressurised gas tanks must not lie horizontal when used during unit operation. Gas outlet in the liquid phase.

REMKO PGM (E) series

Heating mode

1. Move the operating switch to the "I" position.
The supply air fan starts up.



⚠ CAUTION

Before executing the ignition process, check to ensure the correct function of the supply air fan.

2. Push in the pressure pin 2 of the safety pilot and hold down.

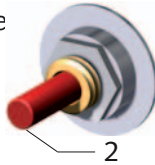

3. With pressure pin 2 depressed, after approx. 2 to 3 sec. actuate the piezo igniter 3.

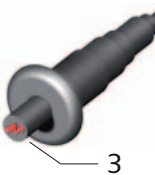

If necessary, actuate the piezo igniter multiple times.

4. After a flame appears, depress the pressure pin 2 for a further approx. 10-15 sec. until the thermal flame monitoring is activated.

5. If the flame goes out when the pressure pin 2 is released, repeat the ignition process.
Observe a waiting time of approx. 1 minute.

With a repeat ignition process, hold the pressure pin for a little longer if necessary.

⚠ CAUTION

The units must not be used below ground level, e.g. in basements, without suitable gas monitoring equipment.

Setting and controlling the heating capacity

The desired or required heating capacity can be steplessly set on the "power regulation".

Turning to the left:
higher heating capacity



Turning to the right:
lower heating capacity

The heating capacity can also be steplessly changed during unit operation.

Safety distances

- For safe operation, a 1 m safety distance must be maintained around the unit
- A minimum distance of 3 m must be maintained from the unit outlet

⚠ CAUTION

It is essential to observe the necessary safe distances from flammable and fire hazardous materials.

- Flooring and ceilings must be fire retardant

⚠ CAUTION

In case of a gas leak, halt unit operation immediately. All gas shut-off valves must be closed and the units disconnected from the power supply.

Ventilate

In this operating mode, the supply air fan runs permanently. The units can be used for air recirculation or ventilation purposes.

1. Close the shut off valve(s) of the gas supply system and allow the gas flame to burn out.



2. Move the operating switch to the "II" (Ventilate) position.



No heating operation is possible in this operating mode.

💡 NOTE

Overpressure and underpressure in the installation area should be avoided as this will inevitably lead to combustion-related faults.

⚠ CAUTION

It must be ensured that supply air can be freely sucked in and that heated air can be blown out without obstruction. The unit intake and outlet must not be restricted or fitted with hoses or pipes.

Shutdown

1. Close the shut off valve(s) of the gas supply system and allow the gas flame to burn out.



2. Move the operating switch to the "0" (off) position.



3. If the units are inactive for longer periods, disconnect them from the mains power supply.

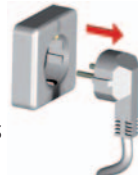

Care and maintenance

NOTE

Regular care and maintenance, at the latest after every heating period, is the basic requirement for a long service life and malfunction-free operation of the units.

In accordance with the operating conditions, the units must be checked as and when required, but at least every **two years**, by a specialist to ensure that they are in a condition that is safe to use.

The results of this test must be recorded in a test certificate. The test certificate must be stored until the next test and presented for inspection by authorised persons on request.

CAUTION

Before undertaking any work on the unit, the gas supply must be shut off and the power plug must be removed from the mains socket.

- Keep the units free of dust and other deposits
- Only clean the units with a dry or moistened cloth
- Never use direct jets of water. **such as high-pressure cleaners etc.**
- Never use abrasive or solvent-based cleaners
- Use only suitable cleaners, even for heavy contamination

- Check the inlet and outlet grille for contamination on a regular basis
- Check hoses and seals for damage on a regular basis
- Replace damaged hoses, seals, etc. immediately
- Clean the gas burner, gas nozzle and the combustion air openings regularly
- Check ignition and ionisation electrodes regularly and adjust and clean if necessary

NOTE

Replace defective or damaged parts immediately and exclusively with original spare parts.

NOTE

Adjustment and maintenance work may only be carried out by authorised and qualified technicians.

CAUTION

An electrical safety check must be carried out in accordance with VDE 0701 after any work on the units.

REMKO PGM (E) series

Disassembling and cleaning the gas burner

1. Switch off the gas supply to the unit and remove the power plug from the mains socket.
2. Remove the protective outlet grille, exterior cladding and inspection cover.
3. Undo the clamping screw 6 of the nozzle holder.
4. Remove the ignition cable from the ignition electrode 4.
5. Detach the capillary tube 3 of the thermocouple from the safety pilot.
6. Loosen the clamping screw 5 on the electrode bracket and carefully draw out the ignition electrode.
7. Carefully pull the thermocouple with capillary tube down and out.
Be aware of the extremely sensitive capillary tube here!
8. Carefully remove any adhered deposits from the ignition electrode and thermocouple.
9. Detach the fastening screws of the gas burner and remove the complete gas burner from the unit.

10. Carefully clean the gas burner with a suitable brush and possibly compressed air.
11. Clean the gas nozzle if necessary.
Do not use any sharp-edged objects!
12. Carefully remove deposits or soiling in the unit base.
13. After all cleaning work on the gas burner, carefully refit all parts in reverse order.
14. After using the gas nozzle, tighten the clamping screw 6 again.
15. Adjust the ignition electrode and thermocouple in accordance with the sketch and tighten the clamping screw 5 of the electrode bracket.
16. Carefully refit all parts of the unit in reverse order.

CAUTION

A functional inspection of the entire unit including leak testing of all gas-conveying connections must be conducted

for example with:

Soap solution or leak detection spray.



Gas burner

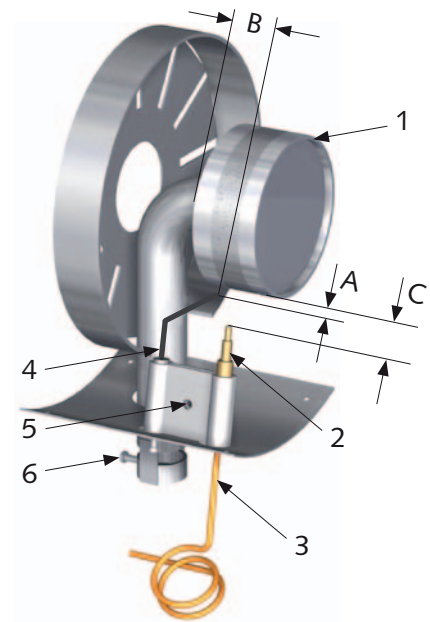

Unit type	A	B	C
PGM 30	approx. 3	approx. 15	approx. 20
PGM 60	approx. 3	approx. 15	approx. 35

All dimensions in mm

Legend:

- 1 = Gas burner
- 2 = Thermocouple
- 3 = Capillary tube
(fixed component of the thermocouple)
- 4 = Ignition electrode
- 5 = Clamping screw (electrodes)
- 6 = Clamping screw (gas nozzle)

NOTE

A strongly yellowy flame indicates an inadequate fresh air supply or dirt inside the unit.

Troubleshooting

Malfunctions:	Cause:
The unit does not start.	1 – 2 – 3 – 4 – 7
The unit switches off during operation.	2 – 4 – 7 – 12 – 13
The fan runs, but the gas supply is blocked or no flame appears.	4 – 5 – 8 – 9 – 12
The flame extinguishes after the pressure pin of the safety pilot is released.	8 – 10 – 11
The gas supply is interrupted, or the flame is extinguished.	4 – 6 – 7 – 10 – 11 – 12 – 13
The unit consumes too much fuel.	12 – 15
The unit cannot be switched off.	3 – 14
The heating capacity drops in permanent operating mode.	13
Cause:	Remedial measures:
1. The unit is not connected to the electricity supply.	Connect the plug with an appropriate socket (230V/50Hz). Replace the plug if it is defective.
2. The fan motor is overloaded or the supply air fan runs irregularly or is blocked.	Check the motor, fan blade and drive clutch.
3. The operating switch is defective.	Replace the operating switch.
4. No gas pressure.	Check whether the gas supply to the unit is present. Check the contents of the gas cylinders. Check the gas hose for damage. Disengage or replace the hose breakage protection.
5. No ignition sparks are generated.	Set the ignition electrode in accordance with specifications. Check the ignition cable. Check the porcelain insulation of the electrode.
6. The protective intake grille of the supply air fan is contaminated.	Clean the protective intake grille.
7. The temperature limiter triggers a switch-off.	Check the protective intake and outlet grilles (clean if necessary). Check whether the fresh air supply is sufficient.
8. The safety pilot does not open the gas supply or keep it open.	Replace the safety pilot.
9. The piezo igniter is defective.	Replace the piezo igniter.
10. The thermocouple or temperature limiter are defective.	Check the thermocouple or temperature limiter and replace if necessary
11. Loose or dirty connection between the safety pilot and thermocouple.	Check the connection and clean if necessary.
12. The pressure controller is defective or an incorrect pressure controller is fitted, or the hose breakage protection (Sbs) has locked.	Fit an original pressure controller. Disengage or replace the hose breakage protection.
13. The gas cylinder(s) is (are) iced up due to an excessively high gas take-off and low temperatures.	Replace the gas cylinder(s) and connect 2-3 cylinders with the multi-cylinder set, EDP no. 1014050.
14. The solenoid valve does not close - Close the gas supply.	Allow the flame to burn out. Set the operating switch to the "0" position and remove the power plug from the mains socket. Replace the solenoid valve.
15. Leaky gas line.	Use foaming media to search for the leak and remedy this.

REMKO PGM (E) series

Intended use

The units are designed exclusively for heating and ventilation purposes in industrial or commercial use (not for living space heating in private use) on the basis of their structural design and equipment.

According to DIN EN 1596, the device definition is "warm air heaters not intended for domestic use without heat exchangers with forced convection".

The units must only be operated by appropriately instructed personnel.

With non-observance of the manufacturer's specifications, the respective local legal requirements or after arbitrary alterations to the units, the manufacturer shall not be liable for resulting damages.

NOTE

*Operation other than the types listed in this operating manual is prohibited.
With non-observance, any manufacturer liability or guarantee claims are voided.*

CAUTION

*Copyright
The redistribution, even in part, or the use of this documentation for purposes other than intended is prohibited without the written authorisation of **REMKO GmbH & Co. KG**.*

Customer service and guarantee

As a prerequisite for any guarantee claims to be considered, it is essential that the ordering party or their representative complete and return the "**certificate of guarantee**" to REMKO GmbH & Co. KG at the time when the units are purchased and commissioned.

The units were tested at the factory several times to verify their correct function.

However, if malfunctions should arise that cannot be remedied by the operator with the assistance of the troubleshooting section, please contact your specialist dealer or contractual partner.

NOTE

Adjustment and maintenance work may only be carried out by authorised and qualified technicians.



Environmental protection and recycling

Disposing of packaging

When disposing of packaging material, please consider our environment.

Our units are carefully packed and delivered in sturdy transport packaging made from cardboard and polystyrene.

The packaging materials are environmentally-friendly and can be recycled.

By recycling packaging materials, you make a valuable contribution to the reduction of waste and conservation of raw materials.

Therefore, only dispose of packaging material at appropriate collection points.

Disposal of the old unit

The manufacturing process for the units is subject to continuous quality control.

Only high-grade materials are processed, the majority of which are recyclable.

You also contribute to environmental protection by ensuring that your old equipment is only disposed of in an environment friendly manner.

Therefore, only bring the old unit to an authorised recycling business or to an appropriate collection point.

REMKO PGM (E) series

Exploded view of PGM 30 (E)

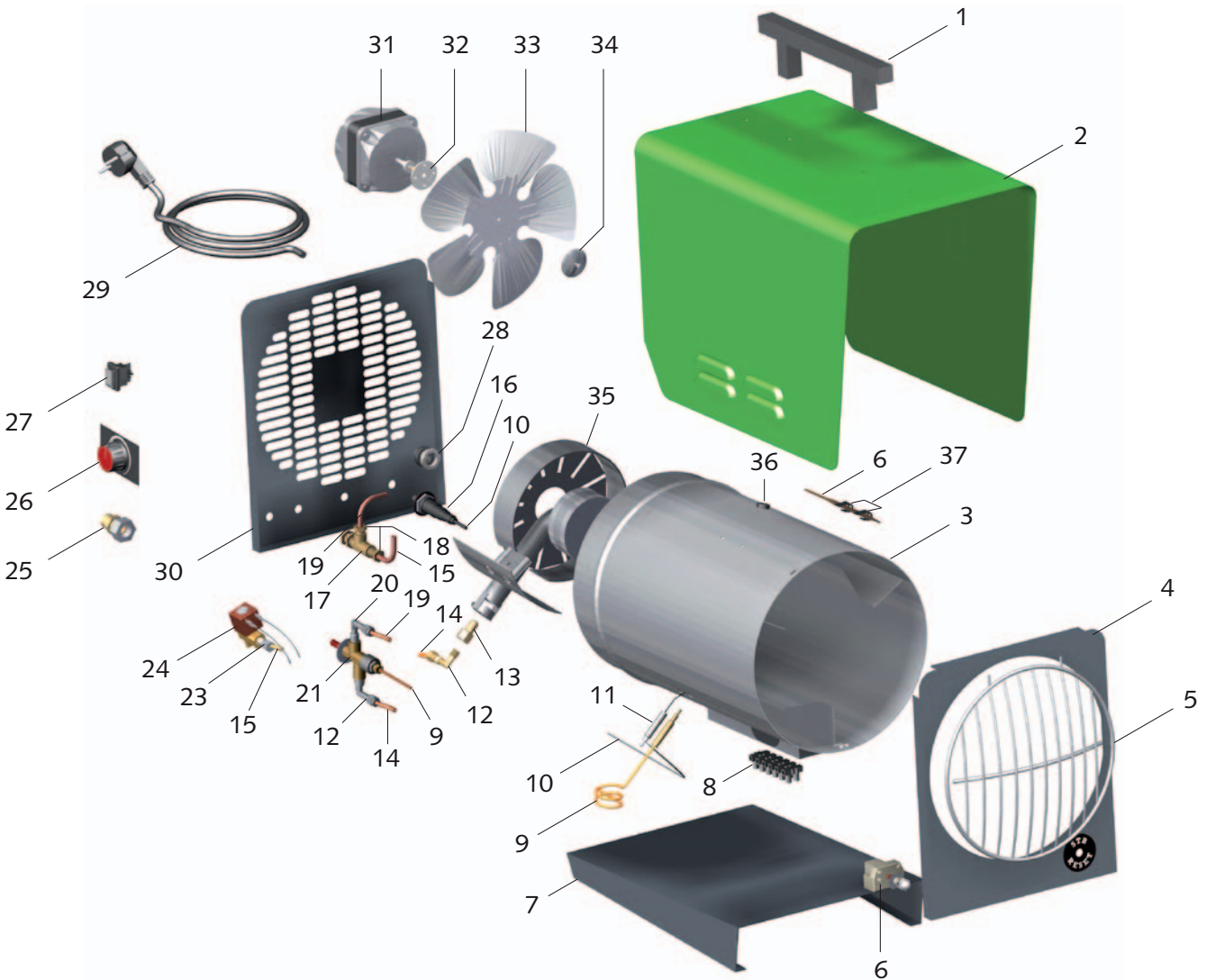

Spare parts list

No.	Description	EDP no.
1	Transport handle	1101142
2	Exterior cladding PGM 30	1101405
2a	Exterior cladding PGM 30 E	1101477
3	Combustion chamber	1121186
4	Completion panel, front	1101479
5	Protective outlet grille	1101383
6	Safety temperature limiter	1101197
7	Inspection cover	1101385
8	Terminal block 6x	1101366
9	Thermocouple	1101164
10	Ignition cable	1101283
11	Ignition electrode	1101180
12	OT elbow union	1101316
13	Gas nozzle	1101159
14	Gas supply pipe Z/D	1101452
15	Gas supply pipe M/R	1101441
16	Piezo igniter	1101364
17	Gas control	1101411
18	Screw connection M10x1	1101409
19	Gas supply pipe R/Z	1101451
20	IT elbow union	1101468
21	Safety pilot	1101169
23	GE-screw connection	1101396
24	Solenoid valve	1101376
25	Gas connection nipple	1101134
26	Adjusting knob, cpl.	1101192
27	Operating switch	1101188
28	Strain relief	1101267
29	Mains cable with plug	1101320
30	Completion panel, rear	1101480
31	Fan motor	1108049
32	Drive clutch B 6 Ø	1108455
33	Fan blade	1101392
34	Clutch plate	1101375
35	Gas burner	1101417
36	Grommet	1101304
37	Retaining clip	1101395
xx	Pressure controller with hose breakage protection	1101470
xx	2 linear m. Gas hose	1101419
xx	2 linear m. HP gas hose (version for construction site operation per DIN 4815 part 1, pressure class 30)	1101174
xx	5 linear m. HP gas hose (version for construction site operation per DIN 4815 part 1, pressure class 30)	1108410
xx	10 linear m. HP gas hose (version for construction site operation per DIN 4815 part 1, pressure class 30)	1108411
xx	Multi-cylinder set (2-3 cylinders)	1014050
xx	T-connection for multi-cylinder set	1101177
xx	Nylon seal for T-connection	1101178
xx	HP hose 0.4 m for multi-cylinder set	1101179

xx = not illustrated

When ordering replacement parts, please always state the EDP no. and unit number (see name plate)!

REMKO PGM (E) series

Exploded view of PGM 60 (E)

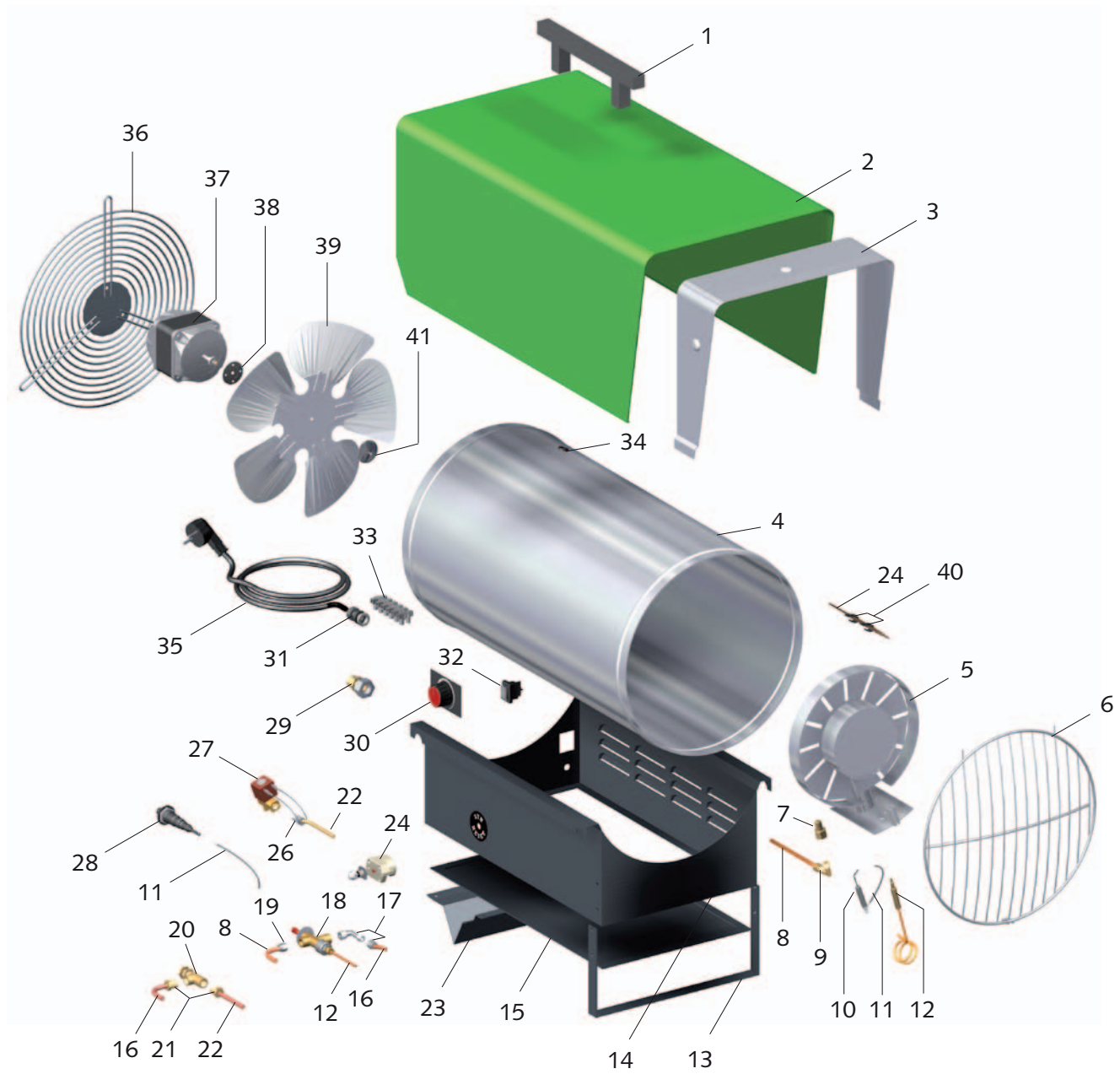

Spare parts list

No.	Description	EDP no.
1	Transport handle	1101142
2	Exterior cladding PGM 60	1101420
2a	Exterior cladding PGM 60 E	1101461
3	Insulation	1101421
4	Combustion chamber	1101422
5	Gas burner	1101423
6	Protective outlet grille	1101424
7	Gas nozzle	1101426
8	Gas supply pipe Z/D	1101458
9	OT elbow union	1101316
10	Ignition electrode	1101280
11	Ignition cable	1101283
12	Thermocouple	1101164
13	Support, front	1101427
14	Unit base	1101428
15	Inspection cover	1101469
16	Gas supply pipe R/Z	1101459
17	IT elbow union	1101468
18	Safety pilot	1101169
19	GE-screw connection	1101359
20	Gas control	1101412
21	Screw connection M10x1	1101409
22	Gas supply pipe M/R	1101441
23	Support, rear	1101249
24	Safety temperature limiter	1101197
26	GE-screw connection	1101396
27	Solenoid valve	1101376
28	Piezo igniter	1101364
29	Gas connection nipple	1101134
30	Adjusting knob, cpl.	1101192
31	Strain relief	1101267
32	Operating switch	1101188
33	Terminal block, 6x	1101366
34	Grommet	1101304
35	Mains cable with plug	1101320
36	Protective intake grille	1101432
37	Fan motor	1101254
38	Drive clutch B 8 ø	1101255
39	Fan blade	1101150
40	Retaining clip	1101395
41	Clutch plate	1101375
xx	Pressure controller with hose breakage protection	1101470
xx	2 linear m. Gas hose	1101419
xx	2 linear m. HP gas hose (version for construction site operation per DIN 4815 part 1, pressure class 30)	1101174
xx	5 linear m. HP gas hose (version for construction site operation per DIN 4815 part 1, pressure class 30)	1108410
xx	10 linear m. HP gas hose (version for construction site operation per DIN 4815 part 1, pressure class 30)	1108411
xx	Multi-cylinder set (2-3 cylinders)	1014050
xx	T-connection for multi-cylinder set	1101177
xx	Nylon seal for T-connection	1101178
xx	HP hose 0.4 m for multi-cylinder set	1101179

xx = not illustrated

When ordering replacement parts, please always state the EDP no. and unit number (see name plate)!

REMKO PGM (E) series

Maintenance protocol



Unit type: Unit number:

	1	2	3	4	5	6	7	8	9	10	11	12	13	14	15	16	17	18	19	20
Unit cleaned - outside -																				
Unit cleaned - inside -																				
Fan blade cleaned																				
Combustion chamber cleaned																				
Gas burner cleaned																				
Ignition electrode adjusted																				
Gas hose checked for damage																				
Gas-transporting parts checked for leak-tightness																				
Safety equipment checked																				
Safety devices checked																				
Unit checked for damage																				
All fastening screws checked																				
Electrical safety check																				
Test run																				

Comments:

1. Date: Signature	2. Date: Signature	3. Date: Signature	4. Date: Signature	5. Date: Signature
6. Date: Signature	7. Date: Signature	8. Date: Signature	9. Date: Signature	10. Date: Signature
11. Date: Signature	12. Date: Signature	13. Date: Signature	14. Date: Signature	15. Date: Signature
16. Date: Signature	17. Date: Signature	18. Date: Signature	19. Date: Signature	20. Date: Signature

Unit to be maintained only by authorised specialists in accordance with the statutory regulations.

Technical data

Series			PGM 30 (E)	PGM 60 (E)
Nominal heat load max.		kW	26.00	55,00
Nominal heat capacity	P_{nom}	kW	26.00	55,00
Minimum heat capacity	P_{min}	kW	10.00	25,00
Air volume flow		m ³ /h	725	1310
Fuel			Liquid gas	
Fuel/gas type			Cat I3P	
Energy efficiency ratio			A	A
Unit connection pressure		bar	1.5	1,5
Unit connection value		kg/h	0.78 - 2.0	1,95 - 4,27
Auxiliary power consumption				
at nominal heating capacity	el_{max}	kW	0.070	0.100
at minimum heating capacity	el_{min}	kW	0.070	0.100
in Standw-By mode	el_{SB}	kW	0.000	0.000
Pilot flame power requirement	P_{pilot}	kW	N/A	N/A
Thermal efficiency at nominal heating capacity	$\eta_{th,nom}$	%	100.0	100,0
Thermal efficiency at minimum heating capacity	$\eta_{th,min}$	%	100.0	100,0
Type of room temperature control			two or more manually adjustable stages, no room temperature control	
Power supply		V/Ph/Hz	230/1~/50	230/1~/50
Rated current consumption		A	0.6	0,95
Electrical protection (provided by the customer)		A	10	10
Enclosure class		IP	11	11
Sound pressure level L_{pA} 1m ¹⁾		dB(A)	56 - 69	62 - 72
Dimensions: Length		mm	450	650
Width		mm	260	320
Height		mm	410	510
Weight		kg	12	20
Product ID number			CE-0085AP0240	

¹⁾ Noise measurement in acc. with DIN 45635 - 01 - KL 3 in heating mode

REMKO PGM (E) series

Electrical wiring diagram

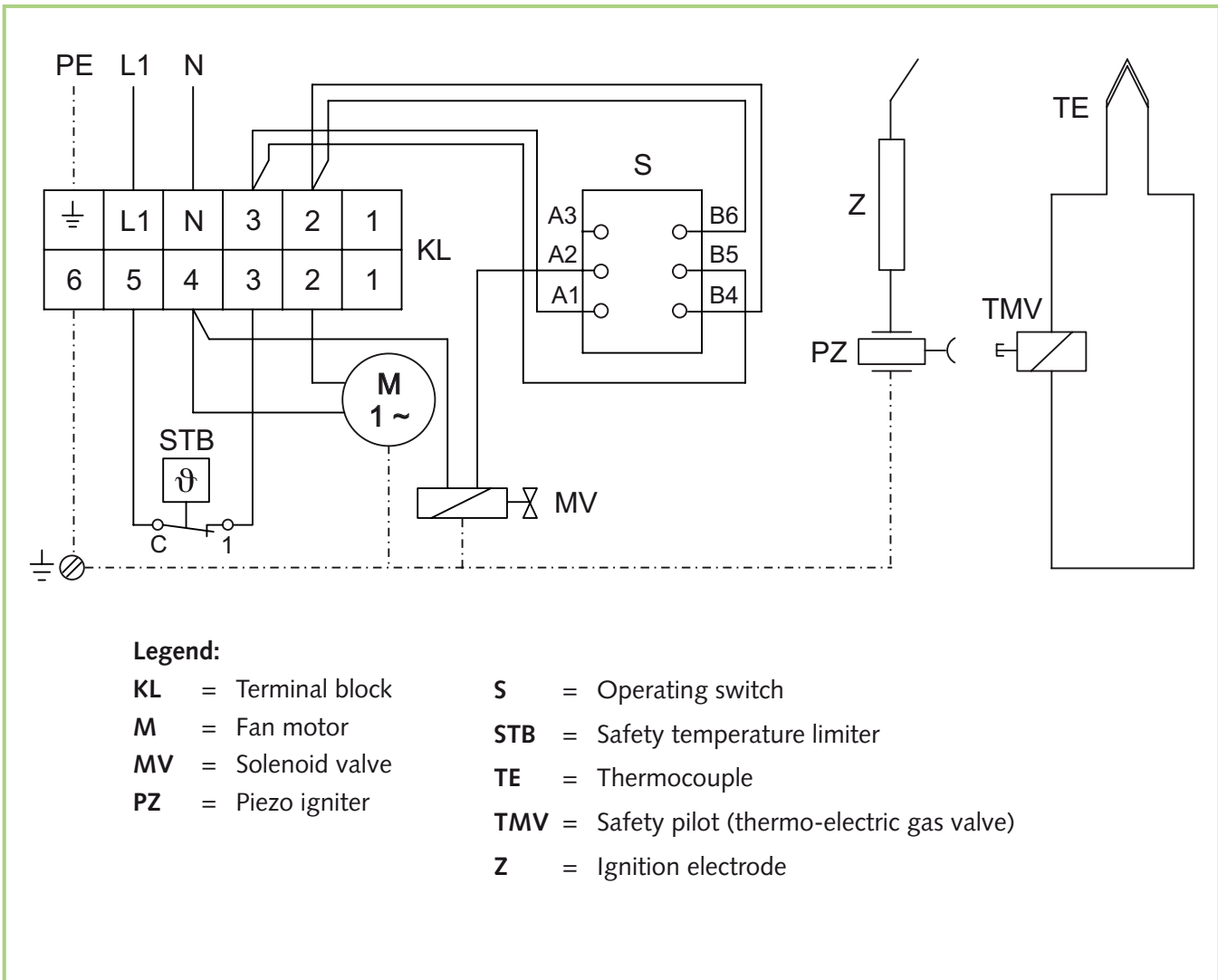



REMKO QUALITY WITH SYSTEMS

Air-Conditioning | Heating | New Energies

REMKO GmbH & Co. KG
Klima- und Wärmetechnik

Im Seelenkamp 12
32791 Lage

Telephone +49 (0) 5232 606-0
Telefax +49 (0) 5232 606-260

E-mail info@remko.de
URL www.remko.de

Hotline within Germany
+49 (0) 5232 606-0

Hotline International
+49 (0) 5232 606-130



We reserve the right to make technical changes, and provide no guarantee as to the accuracy of this data.